

GUARDRAIL



CANADACULVERT™

INNOVATION FLOWS FROM HERE

ENSURING SAFETY ON CANADIAN HIGHWAYS

The economics, versatility, and performance of Guardrail surpass all other roadside barrier systems. Guardrail provides highly-visible protection in all weather conditions helping to increase driver confidence. The Guardrail system absorbs the impact of out-of-control vehicles while guiding the vehicle to safer stops. Proven results and consistent material quality make steel Guardrail systems the right barrier choice.

Economics

- Low initial material costs.
- Straightforward installation and uncomplicated repairs. When repairs are required, only damaged rail or posts need to be replaced. The remaining section of Guardrail still provides effective protection.
- Routine maintenance is not required. Adjustment or tightening is not necessary during the service life of the barrier.
- Systems can have a service life of 30 years or longer.

Versatility

- Applications include parking lots, single and multi-lane highways, bridges and bridge approaches.
- Guardrail systems can be tailored to any application.
- Shop-manufactured rail can be radiused to fit convex and concave curves.
- Rail systems can be designed with wood or steel posts and offset blocks.
- Numerous end treatments are available to meet all design requirements and standards.
- Post to rail ratios can be varied to meet safety requirements.
- Rail thickness is available in 2.8mm (12ga) or 3.5mm (10ga).
- Standard lengths are 3.81m or 7.62m. Custom lengths are available.

Performance

- Minimizes accident severity and injuries when collisions occur.
- Guides vehicle away from the hazard by the “ribbon effect” of the continuous guardrail during vehicle impact.
- Thrie Beam guardrail provides an enhanced performance because of its larger face, which provides reduced deflections and improved resistance to vehicles overturning.
- Meets AASHTO designation M180 specifications. All hardware and components are galvanized according to CSA G164 requirements.

GUARDRAIL IS SAFE, RELIABLE, AND COST EFFECTIVE.

CANADA CULVERT meets all your highway rail requirements:

Guardrail

W-BEAM AND THRIE BEAM GUARDRAIL

CABLE RAIL

END TREATMENTS

WOOD OR STEEL POSTS

HARDWARE

CUSTOM RADIUSED RAILS

ECCENTRIC LOADERS AND EXTRUDER END TREATMENTS



RAIL

W-Beam

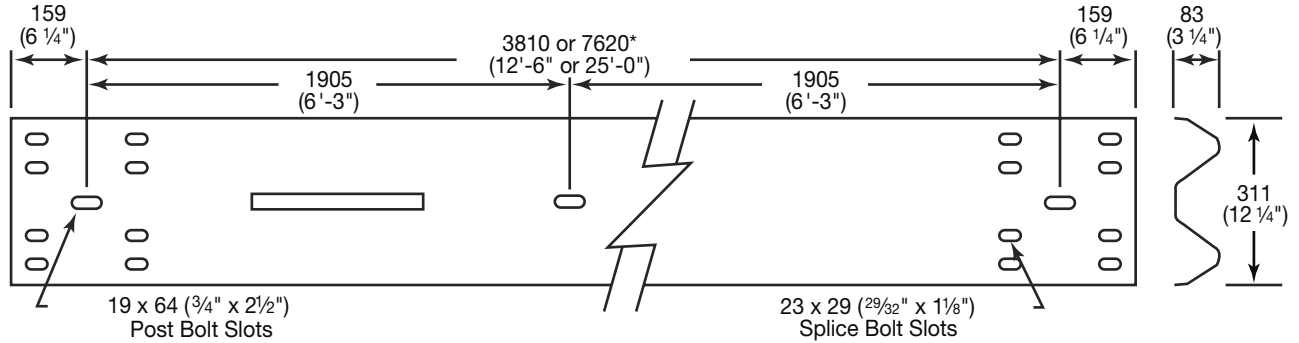

DIMENSIONS AND MECHANICAL PROPERTIES (UNCOATED)		
Thickness (mm)	2.67	3.43
Beam width, minimum (mm)	305	305
Beam depth, minimum (mm)	76	76
Cross-sectional area (mm ²)	1 297	1665
Moment of inertia (mm ²)	973 980	1 252 860
Section modulus (mm ²)	22 778	29 005
Weight (approximate) (kg/m)	10.15	13.05

CENTRE PUNCHING

3810mm	SPACING	7620mm
3810mm	3810mm O.C.	58G
1905mm	1905mm O.C.	60G
952mm	952mm O.C.	61G

BACK-UP PLATE

3G

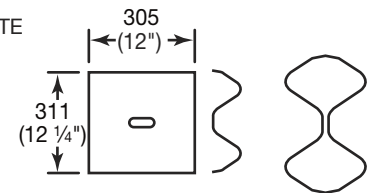

Note: Tubular W-Beam Rail and Components available upon request.

Thrie-Beam

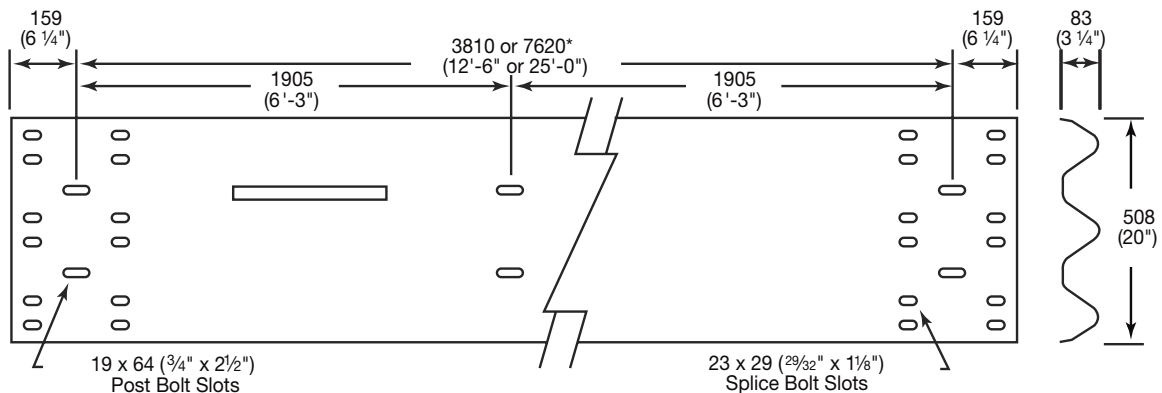

DIMENSIONS AND MECHANICAL PROPERTIES (UNCOATED)		
Thickness (mm)	2.67	3.43
Beam width, minimum (mm)	508	508
Beam depth, minimum (mm)	76	76
Cross-sectional area (mm ²)	2013	2587
Moment of inertia (mm ²)	1 565 000	2 010 000
Section modulus (mm ²)	36 400	47 000
Weight (approximate) (kg/m)	15.63	20.09

CENTRE PUNCHING

3810mm	SPACING	7620mm
3810mm	3810mm O.C.	58G
1905mm	1905mm O.C.	60G
952mm	952mm O.C.	61G

BACK-UP PLATE

203G

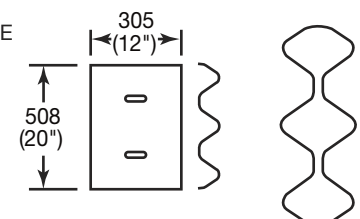

Note: Tubular Thrie-Beam Rail and Components available upon request.

ENDS SECTIONS AND TRANSITIONS

NOMINAL WEIGHT		
	kg	lbs
W-Beam		
901G (2.8mm)	8.2	18
902G (2.8mm)	10.0	22
903G (2.8mm)	10.0	22
926G (3.5mm)	10.0	22
Thrie Beam		
950G (2.8mm)	13.2	24
974G (2.8mm)	30.0	69
975G (3.5mm)	16.8	37

Components are available in 2.8mm (12ga) or 3.5mm (10ga) as required (except where noted).

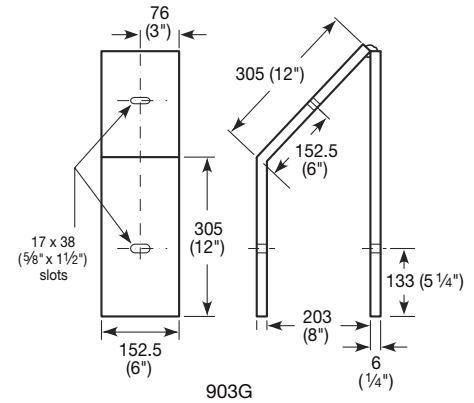

45° Angle Bracket

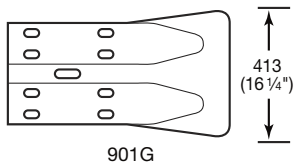

901G

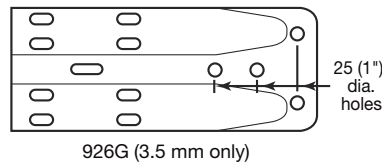

926G (3.5 mm only)

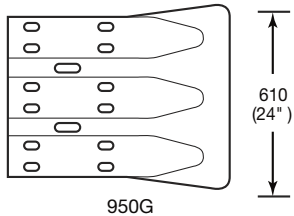

950G

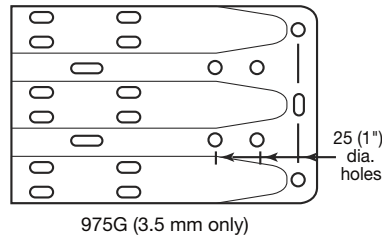

975G (3.5 mm only)

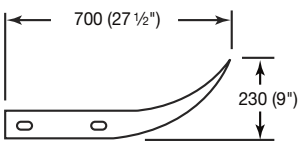

End Section (Flared)

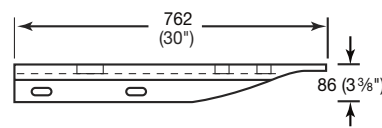

Terminal Connector Parapet

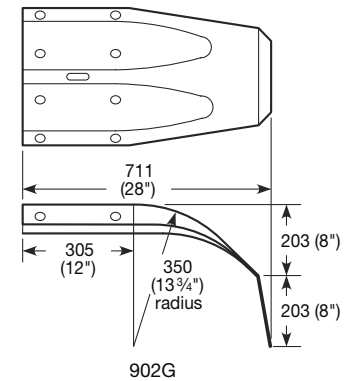

Modified or End (Buried)

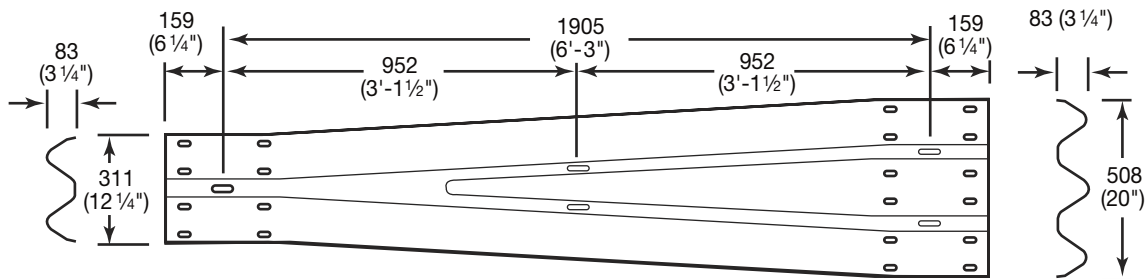

Transition Section from W-beam to Thrie Beam

All dimensions in millimeters (mm).

POSTS AND OFFSETS

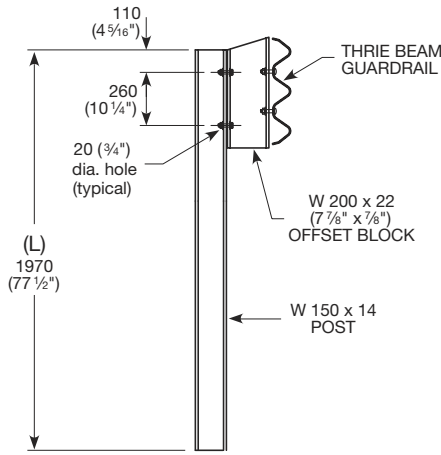

Typical Steel Post, AB

Note: Length (L) and hole punching varies per provincial specifications.

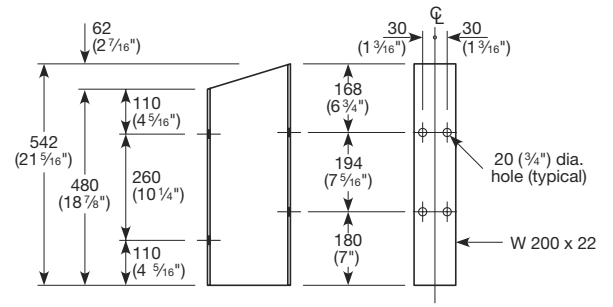

Thrie Beam Offset Block, AB

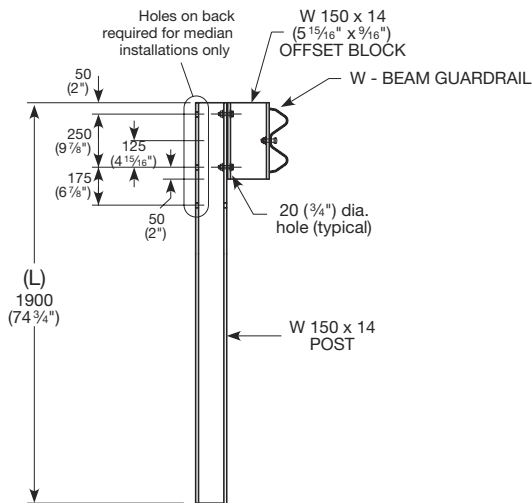

Typical Steel Post, ON

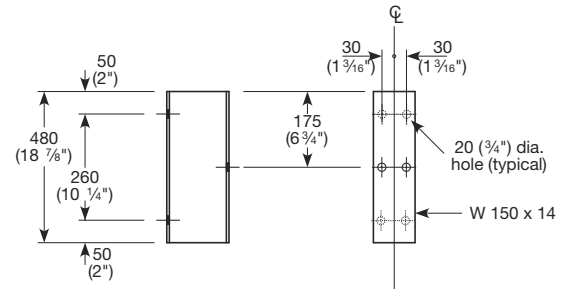

Standard Offset Block, ON

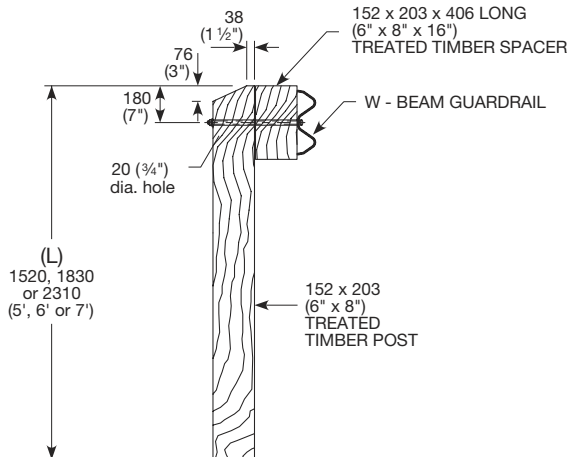

Typical Wood Post, AB

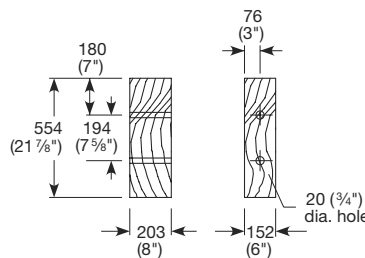

Thrie Beam Spacer Block

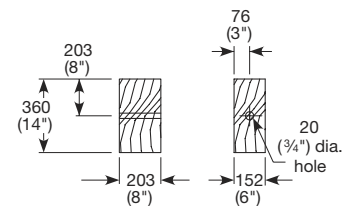

W-Beam Spacer Block

All dimensions in millimeters (mm).

FASTENERS

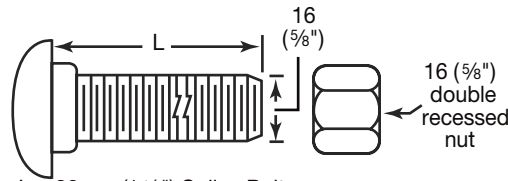

L = 32mm (1 1/4") Splice Bolt
 L = 51mm (2") Steel Post Bolt
 L = 114mm (4 1/2") Rub Rail Post Bolt
 L = 203mm (8"), 267mm (10 1/2"), 406mm (16")
 or 457mm (18") Post Bolt

Button Head Bolts & Hex Nuts

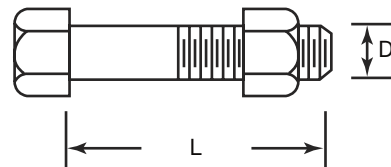
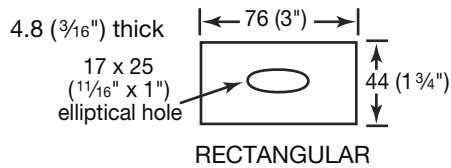
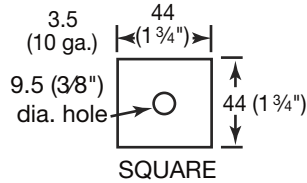
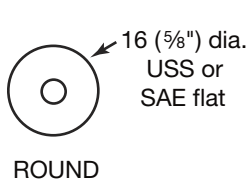

D = 8 mm (5/16"), L = 44 mm (1 3/4")
 D = 13 mm (1/2"), L = 38 mm (1 1/2")
 D = 16 mm (5/8"), L = 38 mm (1 1/2")
 D = 16 mm (5/8"), L = 178 mm (7") or 229 mm (9")
 D = 19 mm (3/4"), 22 mm (7/8"), 25 mm (1") or 32 mm (1 1/4"),
 L = 203 mm (8"), thru 457 mm (18") (or longer)

Washers

Hardware is available hot-dip galvanized or mechanically galvanized.

Hex Head Bolts & Hex Nuts

QUANTITY	MULTIPLY	BY	TO OBTAIN
Length	in	25.4	mm
	ft	0.3048	m
	yd	0.9144	m
	mi	1.609344	km
Area	in ²	645.16	mm ²
	ft ²	0.092903	m ²
	yd ²	0.836127	m ²
	mi ²	2.590	km ²
	acre	4046.87	m ²
	acre	0.404687	ha
Volume	ft ³	0.028317	m ³
	yd ³	0.764555	m ³
	gal	3.785	L
	fl oz	29.574	mL
Mass/unit length	lb/ft	1.48816	kg/m
Mass/unit area	lb/ft ²	4.88243	kg/m ²

QUANTITY	MULTIPLY	BY	TO OBTAIN
Mass	oz	28.35	g
	lb	0.453592	kg
	ton	0.907184	Mg
Density	lb/ft ³	16.0185	kg/m ³
Force	lb	4.44822	N
	kip	4.44822	kN
Pressure	psi	6.89476	kPa
	ksi	6.89476	MPa (N/mm ²)
	lb/ft ³	47.8803	Pa
Velocity	ft/s	0.3048	m/s
	mph	0.4470	m/s
	mph	1.6093	km/h
Torque	ft-lb	1.35582	N•m
Moment of Inertia	in ⁴	416231	mm ⁴
Section Modulus	in ³	16387.064	mm ³
Temperature	°F	5/9(°F-32)	°C

All dimensions in millimeters (mm).

RADIUS GUARDRAIL INFORMATION

Rail sections to be installed on curves having a radius of 1.5m (5 feet) to 45.7m (150 feet) can be curved in our fabricating facilities prior to delivery.

Rail can be curved either convex or concave as required. Terms convex or concave refer to the direction curved, inward or outward, relative to the traffic face of the rail.

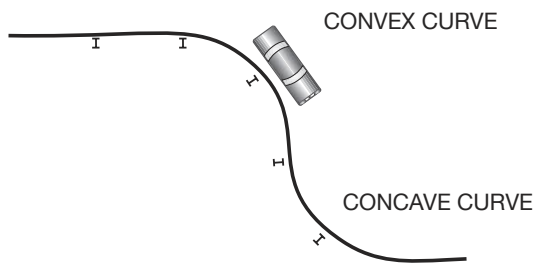

The diagrams & chart provide data for locating posts and curves. For assistance in determining the correct radius, please contact one of our offices.

To find the Radius for a curved rail:

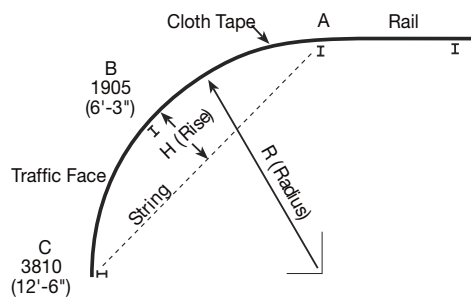

- Step 1: Starting at the last post in the straight run (point A), lay cloth tape along the path that the curved guide rail will follow.
- Step 2: Mark-off two points along the curved cloth tape: one at 1905mm (6'-3") (point B) and the second at 3810mm (12'-6") (point C).
- Step 3: Pull string directly from starting point (point A) to the second mark-off point (point C).
- Step 4: Measure from the first mark-off point (point B) over to the mid-point of the taut string. This measurement (H) is the Rise.
- Step 5: Check the chart to find the Radius (R), given the Rise (H). Example: a Rise of 102mm (4 inches) would result in a Radius of 18.3m (60 feet).

RISE (H)		RADIUS (R)	
(mm)	(inches)	(m)	(feet)
1041	41	1.5	5
914	36	1.8	6
711	28	2.4	8
660	26	2.7	9
559	22	3.1	10
508	20	3.7	12
457	18	4.0	13
406	16	4.6	15
356	14	4.9	16
295	11 5/8	6.1	20
241	9 1/2	7.6	25
197	7 3/4	9.1	30
171	6 3/4	10.7	35
152	6	12.2	40
133	5 1/4	13.7	45
117	4 5/8	15.2	50
108	4 1/4	16.8	55
102	4	18.3	60
92	3 5/8	19.8	65
86	3 3/8	21.3	70
83	3 1/4	22.9	75
76	3	24.4	80
70	2 3/4	25.9	85
67	2 5/8	27.4	90
64	2 1/2	29.0	95
60	2 3/8	30.5	100
54	2 1/8	33.5	110
51	2	36.6	120
44	1 3/4	39.6	130
41	1 5/8	42.7	140
38	1 1/2	45.7	150

Note: Follow the steps left for each piece of rail section in the curved run. The arc may not be consistent and each consecutive piece of rail may differ in radius from the previous one.

All dimensions in millimeters (mm).

British Columbia

Dawson Creek
Genelle
Langley
Prince George

Alberta

Edmonton
Grande Prairie
Ponoka

Saskatchewan

Regina
Saskatoon

Manitoba

Winnipeg

Ontario

Orangeville

TF. 1 (800) 565-1152
canadaculvert.com